

Instant 3 & 7 Hand Wash Unit



The Range

Economical and instant, these hand wash units are compact and simple to operate with a single on/off and temperature control lever. They are also fitted with our unique Vortex spray outlet which eliminates the need for costly maintenance due to the build-up of scale in hard water areas.

Power Output



Approvals



Guarantee



Key Features

- Compact ergonomic design
- Single control lever for on/off and temperature selection
- Vortex spray outlet is non scaling and maintenance free
- 'Heat on' neon indicator
- Swivel 200mm stainless steel spray arm
- Easy clean polar white finish
- Overheat protection
- Fully temperature stabilised
- No standing heat losses
- 3 year guarantee (UK)
- BEAB, WRAS and CE approved

Accessories

- Extended length spray arm, 380mm
- Short length spray arm, 100mm



Unique, maintenance free, non-scaling vortex spray head

Technical

Dimensions

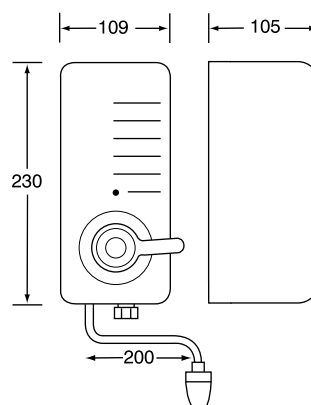

Installation

- Direct connections to water mains
- Standard 15mm pipework
- Top, bottom or rear cable entry
- Standard BSP 1/2" connections
- Full fixing pack supplied

Product Selector

Product Reference	Short Code	Catalogue Number	Heat Setting (kW)	kW Loading @ 230-240V	Recommended Cable Size	Recommended Fuse Rating
Instant 3	I3V	43769715	3	2.7 - 3	1.5mm ²	13 amps
Instant 7	I7V	43769915	7.2	6.6 - 7.2	4 / 6mm ²	30 amps
Extended length spray arm		85768322	-	-	-	-
Short length spray arm		85768330	-	-	-	-

• Operating water pressure 0.7 - 7bar (10 - 100psi) • Water pressure operated power switch

Autosensor Touch-free Hand Wash Unit



The Range

The Autosensor is a unique hand wash unit operated by a no-touch sensor. Ideal for environments where cross-contamination must be avoided, such as hospitals and food preparation areas. The unit is fitted with a unique non-scaling vortex spray outlet and an automatic shut-off to eliminate waste water.

Power Output

3 kW

Approvals



Guarantee



Automatic no-touch sensor

Key Features

- Touch free hygienic operation preventing cross contamination
- Infra-red sensor activates water output for extra economy
- Power on LED indicator
- Timed shut-off set at approximately 20 seconds
- Vortex spray head is non scaling and maintenance free
- Swivel 200mm stainless steel spray arm
- Overheat protection
- Fully temperature stabilised
- No standing heat loss
- Compact ergonomic design
- 3 year guarantee (UK)
- BEAB, WRAS and CE approved

Accessories

- Extended length spray arm, 380mm
- Short length spray arm, 100mm



Unique, maintenance free, non-scaling vortex spray head

Technical

Dimensions

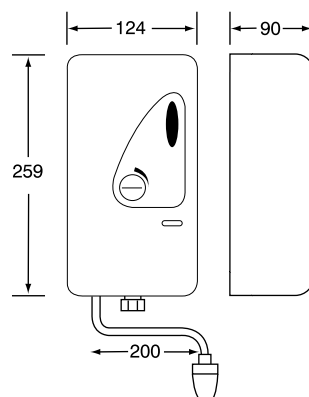

Installation

- Direct connections to water mains
- Standard 15mm pipework
- Top, bottom or rear cable entry
- Standard BSP 1/2" connections
- Full fixing pack supplied

Product Selector

Product Reference	Short Code	Catalogue Number	Touch Free Time Cycle Cut-off	kW Loading @ 240V	Recommended Cable Size	Recommended Fuse Rating
Autosensor	AV3	43591015	20 - 25 seconds	3	1.5mm ²	13 amps
Extended length spray arm, 380mm		85768322	-	-	-	-
Short length spray arm, 100mm		85768330	-	-	-	-

• Operating water pressure 0.7 - 7bar (10 - 100psi) • Water pressure operated power switch



The Range

The Autoflush is a compact, unobtrusive automatic urinal flush controller which maintains hygiene whilst eliminating water wastage as required by Water Bylaw 83. Autoflush requires no electrical mains connection and is supplied with a dedicated long-life lithium battery.

Approvals



Guarantee



Spare battery



Key Features

- A powerful PIR sensor detects when someone approaches the urinals and switches a solenoid valve to open, allowing water to flush to the cistern
- Typical water savings of over 70% per annum. Capital costs maybe recouped in less than two years
- Built-in cleansing flush (every 12 or 24 hours) for maximum hygiene during unoccupied periods
- Choice of 10, 20 or 30 minute timed flow after detection (factory set to 30 minutes)
- No mains electrical connection required, long life lithium battery supplied. Red L.E.D indicates when battery is low
- Typical applications: Offices, Public Conveniences, Hotels, Restaurants, Leisure Facilities, Factories

Accessories

- Vandal proof cover
- Spare Battery
- Note: Water Bylaw 83 states that where urinals are installed there must be a method of controlling the flushing, preventing inflow during times when they are not being used.

Technical

Dimensions

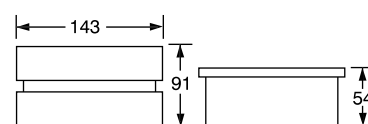

Installation

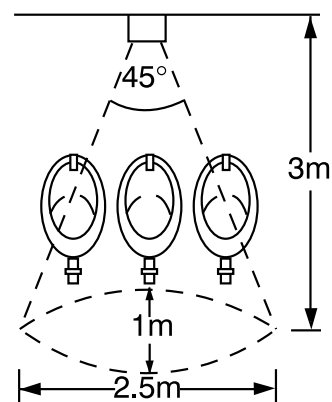

Product Selector

Product Reference	Short Code	Catalogue Number	Sensor	Sensor Range	Battery Pack Supplied	Solenoid Valve
Autoflush	AF1	27900001	Passive infra-red	Up to 4m	10.5V, 3.6Ah lithium long life	9V DC latching (0-12bar)
Spare Battery		96900102	-	-	-	-

• Non-corrosive Polar White ABS plastic box • Water connections: 15mm compression • Recommended Cable: 2 core, CSA 0.5mm² (Outer diameter 5.4mm)
 • Approvals: Restrictors - WRAS, Valve WRAS, Battery UL • Note - Designed to be used with a cistern. Unsuitable for pressurised systems.

Automatic Hand Dryers



The Range

Hygiene is an area where warm air dryers score significantly over paper or linen towels. Germ-free warm air is an extremely hygienic drying medium - with no risk of cross-infection between users. Hand dryers are approved by the Health and Safety Executive as well as the Ministry of Defence for use in commercial and office environments. Also accepted by the National Health Service resulting in increasingly widespread use in British hospitals.

Approvals



Guarantee



Available in white, stainless steel or chrome (as pictured above)

Key Features

AD1 Light to medium installations

- Hand drying only
- Ideal for food preparation areas
- Class 2 insulation, so no need to earth
- Infra-red no 'touch' on/off sensor to prevent cross contamination
- 2 year guarantee (UK)
- IP24 rating
- BEAB and CE approved
- **Available in white or chrome**

AD10 Light to medium installations

- Hand drying only
- Ideal for surgeries, clinics and veterinary practices
- Fully automatic
- UK manufactured
- 3 year guarantee (UK)
- IP21 rating
- BEAB and CE approved
- **Available in white or chrome**

AD10S Light to medium installations

- Hand drying only
- Stainless steel cover
- Easy to clean
- Fully automatic
- UK manufactured
- 3 year guarantee (UK)
- IP21 rating
- BEAB and CE approved

Technical

Dimensions

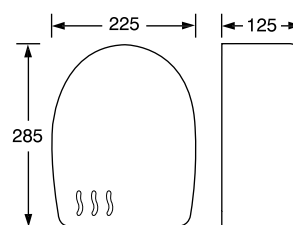

Dimensions AD1

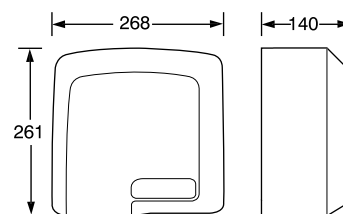

Dimensions AD10

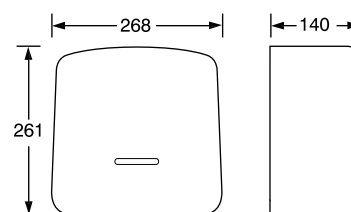

Dimensions AD10S

Product Selector

Product Reference	Short Code	Catalogue Number	Weight (Kg's)	Total Loading @ 240V	Motor Watts	Fan Motor Speed (RPM)	Air Volume M3/Hr	Air Velocity M/Sec	Peak Air Temp Rise °C	Noise Level at 1 mtr cb (A)
Autodry1	AD1	56751501	1.9	1.5 kW	60	2500	120	15	60	63
Autodry1Ch	AD1Ch	56751570	1.9	1.5 kW	60	2500	120	15	60	63
Autodry10	AD10	56750540	2.5	1.7 kW	100	2400	180	18	40	67
Autodry10Ch	AD10Ch	56750570	2.5	1.7 kW	100	2400	180	18	40	67
Autodry10S	AD10S	56750541	2.5	1.7 kW	100	2400	180	18	40	67

• Heating element closed coil nickel chromium wire • Sensor range 150mm • Impact resistant plastic

Automatic Hand & Face Dryers



The Range

The reliable range of Redring automatic dryers provides efficient and hygienic hand and face drying. With fully automatic operation the AD20 is ideal for installation where noise needs to be kept at a minimum whilst the AD30 provides increased airflow for faster hand and face drying. For installation at the busiest washrooms the AD50 is highly durable making it ideal for installations in airports, factories and motorway service stations.

Approvals



Guarantee



Available in White and Chrome
(as pictured at top of page)

Key Features

AD20 Medium use installations

- Hand and face drying
- Quiet operation – ideal for hospital wards or libraries
- Fully automatic
- Cover cast aluminium alloy with epoxy paint
- UK Manufactured
- 3 year guarantee (UK)
- IP23 rating

AD30 Medium use installations

- Hand and face drying
- Fast drying time – ideal for restaurants and hotels
- Fully automatic
- Cover cast aluminium alloy with epoxy paint
- UK Manufactured
- 3 year guarantee (UK)
- IP23 rating
- **Available in white or chrome**

AD50C High use installations

- Hand and face drying
- High volume air-flow for faster drying
- Ideal for motorway services, factories, schools & sports centres
- Fully automatic
- Cover cast iron vitreous enamelled
- UK Manufactured
- 3 year guarantee (UK)
- IP23 rating

Technical

Dimensions

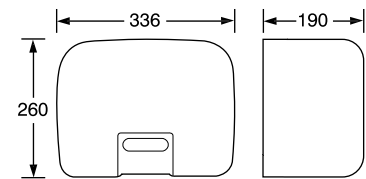

Dimensions AD20

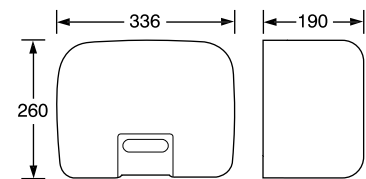

Dimensions AD30

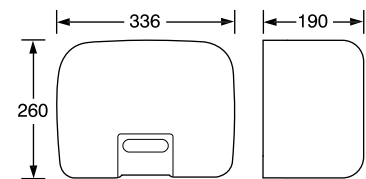

Dimensions AD50C

Product Selector

Product Reference	Short Code	Catalogue Number	Weight Kg	Total Loading @ 240V	Motor Watts	Fan Motor Speed RPM	Air Volume M3/Hr	Air Velocity M/Sec	Peak Air temp Rise °C	Noise Level at 1 mtr cb (A)
Autodry20	AD20	56751303	6.5	2 kW	60	2800	150	12	50	64
Autodry30	AD30	56751404	6.5	2.4 kW	200	6000	220	22	50	78
Autodry30Ch	AD30Ch	56751470	6.5	2.4 kW	200	6000	220	22	50	78
Autodry50C	AD50	56751118	15	2.5 kW	300	7000	250	25	50	78

• Sensor range 150mm